

Step one: Installation of the fuel tank cover

Name	Quantity	Standard	Remark
pipe	1		In the accessory case
cover, fuel tank	1		On the bike



Instruction for the installation:

Take out from the accessory case, and then screw down on .

Step two: Installation of the handle bar

Name	Quantity	Standard	Remark
Bolt	4	M8 × 35	In the accessory case
Handle bar seat	1		On the bike
Handle bar clip	2		In the accessory case
Handle bar	1		In the packing chest

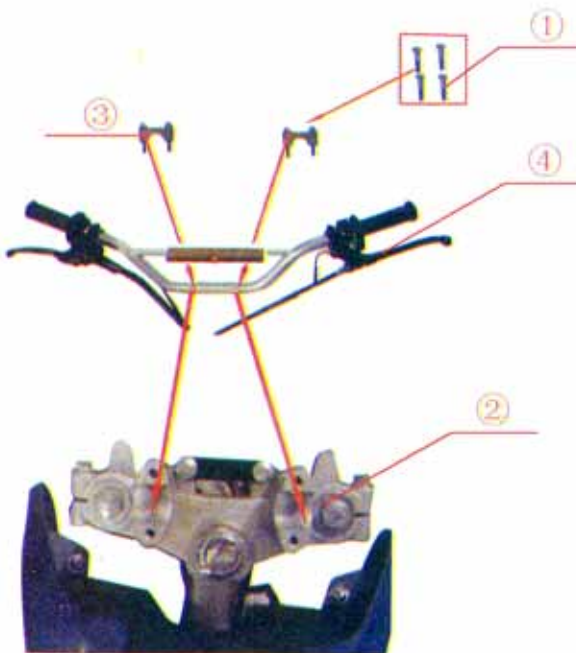

Instruction for the installation:

1. Take out and from the accessory case; then using and fix to .

Attention:

must be fix in the gear of .

Step three: Installation of the protect cover for handle

Name	Quantity	Standard	Remark
Protect cover for handle	2		In the accessory case
Cover fixing seat	1		In the accessory case
Handle	1		In the packing chest
Bolt	4	M6 × 16	In the accessory case
Clip	2		In the accessory case
Bolt	4	M6 × 28	In the accessory case



Instruction for the installation:

1. Fix in and with .
2. Fix and in with .

Step four: Installation of the rear shock absorber

Name	Quantity	Standard	Remark
Bolt	1	M12 × 120	In the accessory case
Nut	1	M12	In the accessory case
Swing frame	1		
Swing arm	1		



Instruction for the installation:

1. Fix in with and .

Step five: Installation of the gear shift & side stand



Name	Quantity	Standard	Remark
Gear shift	1		In the accessory case
Bolt	1	M6 × 20	In the accessory case
Axle, gear shift	1		On the bike
Upper hole, side stand	1		
Bolt	2	M12 × 25	In the accessory case
Fix hole, side stand	1		
Lower hole, side stand	1		In the packing chest
Upper fixing hole, side stand	1		

Instruction for the installation:

1. Fix in with ;
2. Fix & in & with , to , to .

Step six: Installation of the faceplate & front fender



Name	Quantity	Standard	Remark
Bolt	1	M6 × 16	In the accessory case
Faceplate	1		In the accessory case
Lower support, Fr, fender	1		
Lower joined plate	1		
Fr, fender	1		In the accessory case
Bolt	2	M6 × 20	In the accessory case
Bush	1		In the accessory case
Bolt	1	M6 × 16	In the accessory case
Upper support, front fender	1		

Instruction for the installation:

1. Put on , then fix in with ;
2. Fix in with 、 、 .

Step seven: Installation of the front wheel

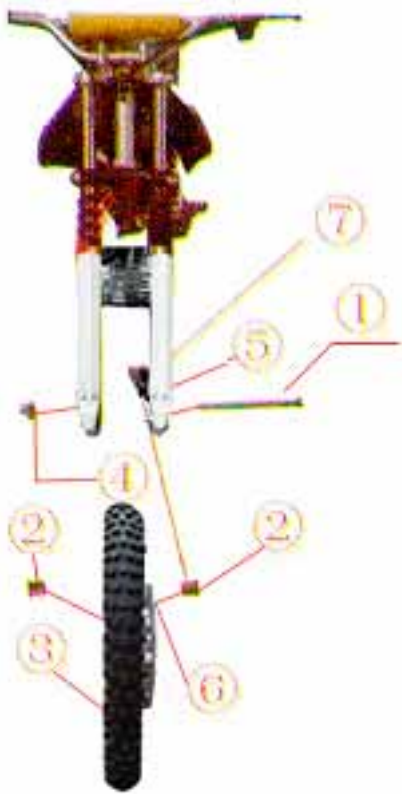

Name	Quantity	Standard	Remark
Front wheel axle	1	M12 × 270	On the bike
Bush	2	L : 33.6	In the accessory case
		R : 25.6 × \varnothing 12 × \varnothing 24	
Front wheel	1		In the packing chest
Nut	1	M12	On the bike
Front shock absorber	1		On the bike
Disc brake plate	1		On the front wheel
Pump disc brake	1		On the front shock absorber

Instruction for the installation:

1. Remove upper rubber, clip into ;
2. Fix and into with , and then screw down with .

Step eight: Installation of the battery



Name	Quantity	Standard	Remark
Electrolyte	1	M6 × 16	In the accessory case
Battery	1		In the accessory case
Rubber plug	1		In the accessory case
Sald cover	1		On the seat
Seat screw	2		On the bike
Seat	1	M6 × 20	On the bike
Bundling band	1		In the accessory case
Battery box	1	M6 × 16	On the bike
Battery cable	2		On the bike

Instruction for the installation:

1. Put into , then seat it with , please refer to the electrolyte instruction.
2. Remove , remove and .
3. Put in the right position of .
4. Connect with .
5. Then fix on with .

Attention:

The battery includes positive and negative lead, the battery cable includes red cable and green cable. Please be noted that the red cable should be connected with the positive lead, while green cable with negative lead when connecting.